

Newton Gateway

Technical Details

Dimensions (mm)	243.0 x 243.0 x 45.57
Model	EGS500DB0X/WWW
CPU	CortexA9Dual 1.2GHz
Flash Memory	4GB
RAM	1GB
RF MEDEM	2.4GHz & Sub-G
Interface	Ethernet
Power Consumption	10W
Capacity (2.9" BWR)	50,000*1page
Coverage (Indoor in radius)	UP to 30m

Technical Drawing

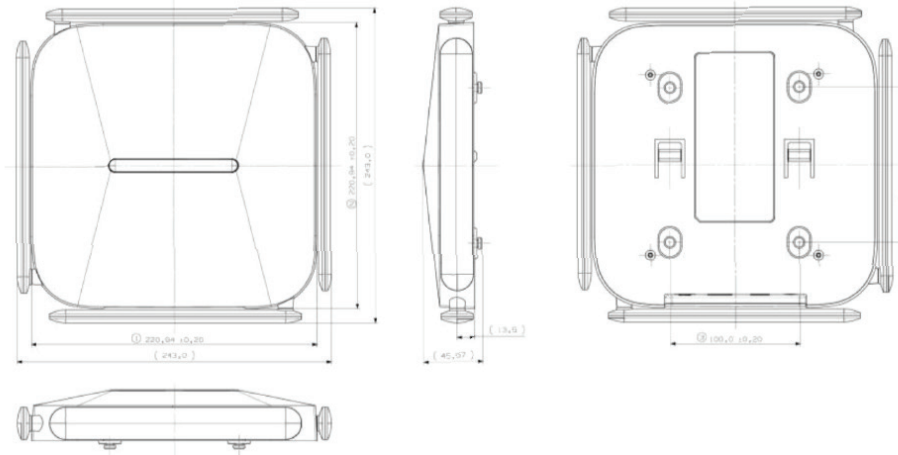

Newton Gateway



e-shelf-labels | S&K Solutions GmbH

Sailerwöhr 16 | 94032 Passau
+49 (0) 851 / 2009 30 30

info@e-shelf-labels.com
www.e-shelf-labels.com

a brand of 
solutions